

S9056RT-HC/S9070RT-HC

ULTRA-HIGH CAPACITY ROUGH TERRAIN SCISSOR LIFTS



- Ultra-high capacity, large deck rough terrain scissor lifts
- Excellent rough terrain performance
- Heavy duty design
- Dual powered extension decks
- Ideal for construction applications

 **snorkel**™
www.snorkellifts.com

ULTRA-HIGH CAPACITY ROUGH TERRAIN SCISSOR LIFTS

S9056RT-HC/ S9070RT-HC

DIMENSIONS	S9056RT-HC*	S9070RT-HC*
Max. working height	62 ft	76 ft
Max. platform height (A)	56 ft	70 ft
Platform size (stowed)	18 ft x 7 ft 4 in	
Platform size (extended)	27 ft x 7 ft 4 in	
Extension deck length	4 ft 8 in	
Overall width (B)	7 ft 6 in	
Overall length (C)	18 ft	
Stowed height (D)	10 ft 2 in	11 ft 3 in
Min. height (guardrails folded)	7 ft	8 ft 5 in
Ground clearance	9 in	

PERFORMANCE	S9056RT-HC*	S9070RT-HC*
Platform capacity (SWL)	3,000 lbs	2,000 lbs
Max. drive height	43 ft	
Max. wind speed	28 mph	
Max. drive speed (stowed)	4 mph	
Max. drive speed (elevated)	0.3 mph	
Raise/lower time	63/58 sec	98/78 sec
Gradeability	50%	
Max. stabilizer levelling, front to rear	7°	
Max. stabilizer levelling, side to side	12°	
Inside turning radius	8 ft	
Outside turning radius	18 ft 6 in	
Tires	13 x 36 foam filled	
Controls	proportional joystick	
Drive system	4-wheel drive	

POWER	S9056RT-HC*	S9070RT-HC*
Power source	Kubota diesel	

WEIGHT	S9056RT-HC*	S9070RT-HC*
Weight	20,000 lbs	25,500 lbs

TURNING RADIUS

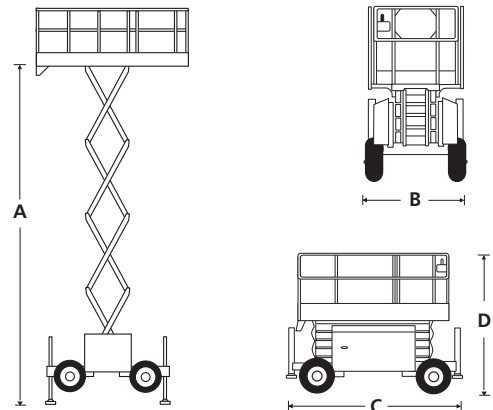
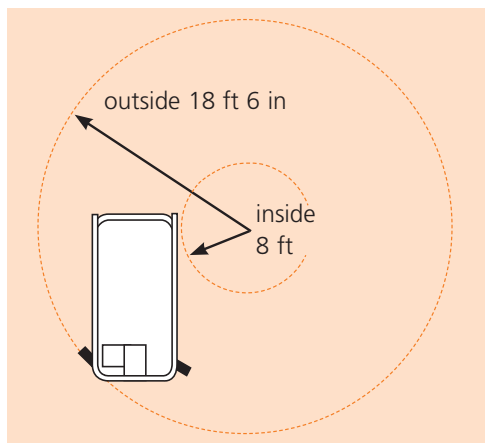

STANDARD FEATURES

- 4-wheel drive
- 4 hydraulic stabilizers with automatic levelling
- Dual powered extension decks
- Proportional controls
- Foam filled tires
- Power line to platform
- Platform overload system
- Drive motion alarm
- Descent alarm
- Locking, oscillating axle
- Fold-down guardrails
- Manual lowering valve
- Flashing amber light (x2)
- Dual lanyard attachment points
- Hour meter & on-board diagnostics display
- 2 year parts & labor, 5 year structural warranty
- ANSI compliant

OPTIONS

- Special paint colors
- Nylon spreader pads (set of 4)
- Environmental hydraulic oil
- Dual fuel
- Non-marking foam filled tires
- Cold weather package (block heater + battery blanket)
- Hydraulic 110V 2kW generator
- 12kW generator package

snorkel www.snorkellifts.com

P.O. Box 1160
St. Joseph, MO 64502-1160, USA
Tel: 1 (785) 989-3000
Toll-free: 1 (800) 255-0317
Fax: 1 (785) 989-3070
Email: sales.usa@snorkellifts.com