



A two-in-one attachment for clamp and pallet handling.

APPLICATIONS

Cascade's TURNAFORK™ is used in a variety of manufacturing, receiving, warehousing and shipping environments that require both clamp handling and pallet handling. Rotate the arms to the vertical position for clamping, or to the horizontal position to handle most types of conventional pallets. Order picking layers of varied product onto a pallet is simplified. In addition to clamp handling of cartons, the versatile TURNAFORK™ is also used for clamping awkward or difficult loads such as large tires.

FEATURES

- Proven, durable arm and aluminum frame construction insuring long, useful life of the clamp
- Superior arm-slide bearing material for extended bearing life
- Replaceable rubber-faced arm pads
- Integral sideshifting
- Regenerative hydraulic circuit for optimal arm speed

OPTIONS

- Application-specific arm sizes
- Application-specific arm facing
- Load backrests
- Class III mounting
- Quick Disconnect mounting
- Modified opening range
- Hydraulically rotating/positionable forks (see reverse side)



Arms in fork position for pallet handling.



Arms in vertical position for clamping.

*Cascade's
TURNAFORK™
handles a wide
variety of loads.*

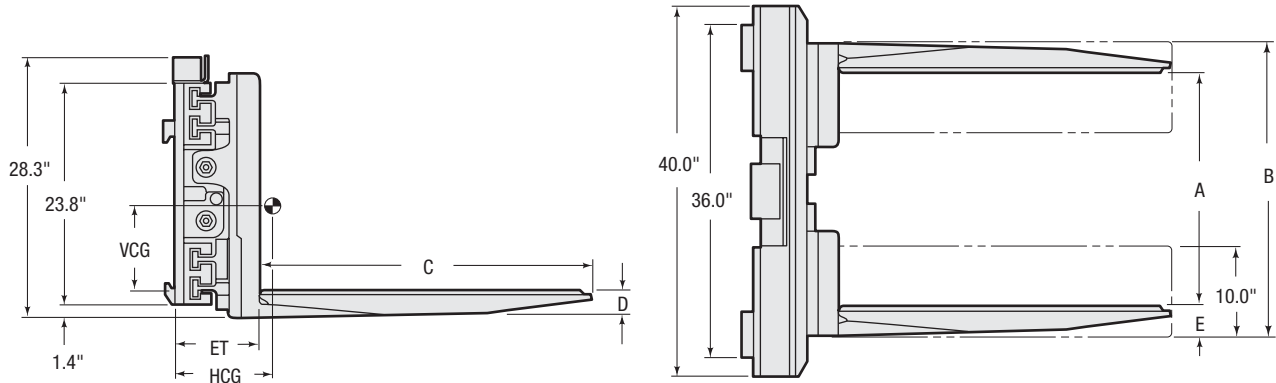

Sideshifting

Capacity @ 24" (600 mm) Load Center		Clamp Opening Range		Fork Opening Range ①		Catalog Order No.	Mtg. Class	Weight		Effective Thickness ET	Horizontal Ctr. of Gravity HCG	Vertical Ctr. of Gravity VCG	Arm Length C	Arm Thickness D	Arm Thickness (w/Toe-In) E
lbs	kg	A	B	lbs	kg										
4,000	1,815	20.9"-63.7"	27.3"-70.8"	40D-CTS-11A	II	1,170	531	9.1"	10.5"	6.7"	36"	2.4"	3.3"		
4,000	1,815	20.9"-63.7"	27.3"-70.8"	40D-CTS-11B	III	1,220	554	9.3"	10.4"	6.8"	36"	2.4"	3.4"		
4,000	1,815	20.6"-63.4"	27.3"-70.8"	40D-CTS-12A	II	1,185	538	9.1"	11.1"	6.6"	42"	2.4"	3.4"		
4,000	1,815	20.6"-63.4"	27.3"-70.8"	40D-CTS-12B	III	1,230	558	9.3"	11.0"	6.7"	42"	2.4"	3.4"		
4,000	1,815	20.3"-63.1"	27.3"-70.8"	40D-CTS-13A	II	1,205	547	9.1"	11.8"	6.5"	48"	2.4"	3.4"		
4,000	1,815	20.3"-63.1"	27.3"-70.8"	40D-CTS-13B	III	1,250	568	9.3"	11.7"	6.6"	48"	2.4"	3.4"		

① Out to Out.

Options

- Tire Handling Forks
- Modified Fork/Pad Size

Hydraulically Positionable Fork Option

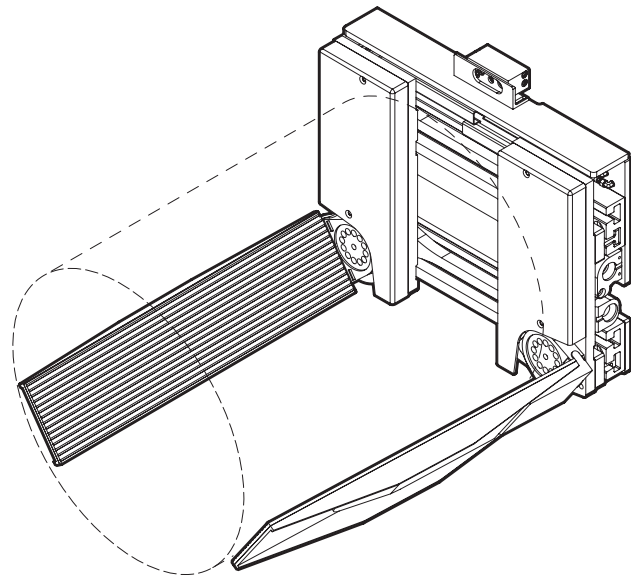

Hydraulically positionable forks allow positioning at 45° for “cradling” loads. (Requires one additional hydraulic function) **Consult Cascade**

INSTALLATION KIT

Catalog Order No.

659249

HYDRAULIC FLOW AND PRESSURE

Minimum	Recommended	Maximum	Maximum Pressure
7 GPM	7 GPM	10 GPM	2,300 PSI

HYDRAULIC FUNCTIONS

Model	Hydraulic Functions	Truck Auxiliary Valves Required
Standard Unit	2	2
Hydraulically Positionable Forks	3	3

MOUNTING CLASS INFORMATION

Mounting Class	Truck Capacity
II	2,000-5,500 lbs.
III	6,000-10,000 lbs.