



## STANDARD SPECIFICATIONS

### Performance

Platform Height	50-ft .5-in / 15.2-m
Horizontal Outreach	31-ft 6-in / 9.6-m
Centerline to Platform Edge	31-ft / 9.45-m
Swing	410 Degrees Non-Continuous
Platform Capacity	500-lb / 227-kg
Platform Capacity w/Rotator (Optional)	440-lb / 200-kg
Material Hook Capacity	500-lb / 227-kg
Platform Rotator	90 Degrees Manual
Jib Length	4-ft / 1.22-m
Jib Vertical Motion	130 Degrees (+75, -55)
Weight*	5,200-lb / 2,359-kg
Leveling Capability	11 Degrees
Max. Ground Bearing Pressure	31 psi / 2.18 kg/cm <sup>2</sup>
Towing Speed Rating	65 mph / 105 km/h
Tongue Weight*	450-lb / 204-kg
Max Gradability	20%
Hydraulic Reservoir	6.0 gal / 22.71 L

\*Certain options or country standards increase weight

### Power Source

DC Power	24V DC
Gasoline Engine	Honda GX 270

### Tires

Standard	ST225/75 R15 Pneumatic
----------	------------------------

## KEY SPECS

**Platform Height**  
50-ft .5-in / 15.2-m

**Towing Speed**  
65 mph / 105 km/h

**Horizontal Outreach**  
31-ft 6-in / 9.6-m

**Platform Capacity**  
500-lb / 227-kg

## KEY FEATURES

- Optimize productivity with 11.7 hp gasoline engine.
- New standard features include a smart charger, LED tail lights, lockable hoods, dual USB port in platform and parking brake audible indicator
- Set up with ease and get right to work with hydraulic, auto-leveling outriggers.
- Detachable platform controls provide efficient boom positioning with one-hand operation of all boom functions.

## STANDARD FEATURES

- 110V-AC Receptacle in the Platform
- LED Taillights & Mounting Bracket
- Lockable Hoods
- Motion Alarm
- Parking Brake Audible Indicator (COMING EARLY 2025)
- Platform, Side Entry: 30 x 48-in (0.76 x 1.22-m)
- Proportional Controls
- Hydraulic Surge Brakes
- Quick Start Guide Common Among all JLG® Towable Boom Models
- Smart Charger
- Standard Air and Water Lines to Platform
- Telescopic Upper Boom
- Tilt Alarm/Indicator Light

## ACCESSORIES & OPTIONS

- 3000W Honda Generator (Aftermarket Only)
- Full-Size Spare Tire
- Lifting Lugs
- Material Hook — 500-lb / 227-kg Capacity
- Platform Rotator

## DIMENSIONS

All dimensions are approximate

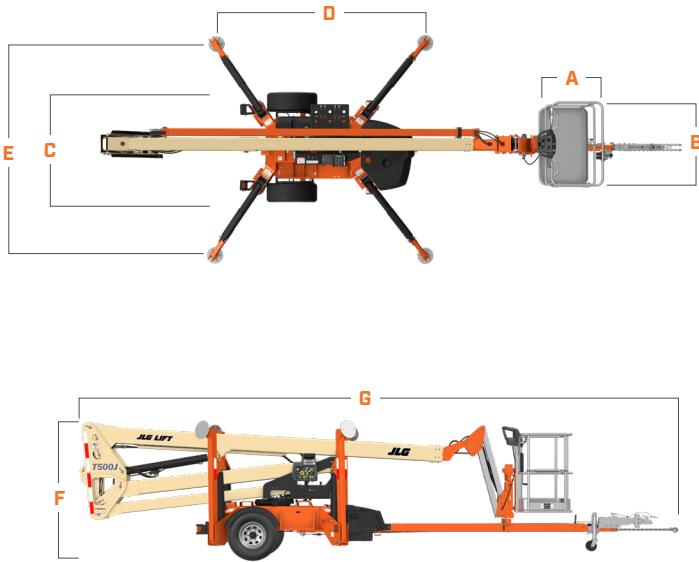

- A. Platform Width 30-in / 0.76-m
- B. Platform Length 48-in / 1.22-m
- C. Machine Width 5-ft 7.5-in / 1.7-m
- D. Outrigger Footprint Length 12-ft 4-in / 3.8-m
- E. Outrigger Footprint Width 12-ft 8-in / 3.9-m
- F. Machine Height 6-ft 6.75-in / 2-m
- G. Machine Length 27-ft 3.75-in / 8.32-m<sup>1</sup>

<sup>1</sup> With surge brake, 2-in ball

## REACH DIAGRAM

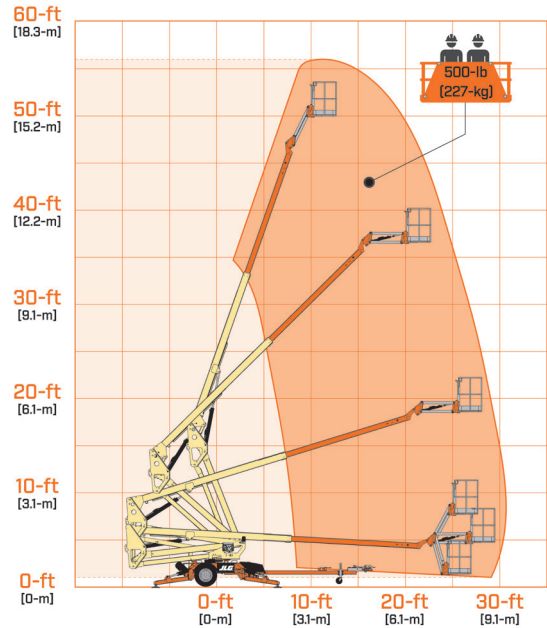

We provide coverage for one (1) full year, and cover all specified major structural components for five (5) years. Due to continuous product improvements, we reserve the right to make specification and/or equipment changes without prior notification. This machine meets or exceeds applicable ANSI and CSA requirements based on machine configuration as originally manufactured for intended applications. Please reference the serial number plate on the machine for additional information.



**JLG INDUSTRIES, INC.**  
Toll-free US 877-JLG-LIFT  
**JLG.com**

An Oshkosh Corporation Business