

ES2646

ELECTRIC SCISSOR LIFT

SCISSOR LIFT



STANDARD SPECIFICATIONS

Performance	Indoor	Outdoor
Platform Height (Elevated)	26-ft / 7.92-m	26-ft / 7.92-m
Platform Capacity	1,200-lb / 545-kg	1,200-lb / 545-kg
Capacity on Platform Extension	265-lb / 120-kg	265-lb / 120-kg
Number of Occupants	2	1
Lift / Lower Time (No Load)	49/44 seconds	49/44 seconds
Lift / Lower Time (Rated Load)	62/37 seconds	62/37 seconds
Maximum Drive Height	Fully Elevated	Fully Elevated
Weight*	5,295-lb / 2,401-kg	5,295-lb / 2,401-kg
Max. Ground Bearing Pressure	137 psi / 9.6 kg/cm ²	137 psi / 9.6 kg/cm ²
Drive Speed (Lowered)	3 mph / 4.8 km/h	3 mph / 4.8 km/h
Drive Speed (Raised)	0.5 mph / 0.8 km/h	0.5 mph / 0.8 km/h
Gradeability	25%	25%
Max Tilt Rating (Side-to-Side)	2.5 Degrees	1.5 Degrees
Max Tilt Rating (Fore and Aft)	3.5 Degrees	3.5 Degrees
Turning Radius (Inside)	Zero	Zero
Turning Radius (Outside)	88-in / 2.2-m	88-in / 2.2-m

*Certain options or country standards increase weight

KEY SPECS

Platform Height
26-ft / 7.92-m

Platform Capacity
1,200-lb / 545-kg

Number of Occupants
Indoor: 2
Outdoor: 1

Stowed Drive Speed
3 mph / 4.8 km/h

KEY FEATURES

- The 1200-lb indoor and outdoor platform capacity beats the competition.
- Refreshed design delivers electric drive, for up to double the battery life of a standard scissor.
- Work in sensitive areas with optional CleanGuard leak containment system.
- Features a standard USB charger and phone holster, improving the operator experience while delivering a high degree of commonality with other JLG® scissors to simplify service.

Power

Batteries	4 x 6V 220 amp-hr
Charger	27 Amp
Drive	24V AC

Tires

Standard	16 x 5-in / 406 x 125-mm
----------	--------------------------

Brakes

Multi-Disc Friction

Hydraulic System

Capacity	1.7 gal / 6.4 L
Pump	Fixed Displacement Gear

STANDARD FEATURES

- 27 amp Multi-Function Universal Charger
- AC Receptacle in Platform
- Active Pothole Protection System
- All Motion Alarm
- Analyzer Port for Diagnostics
- Battery Condition Indicator
- CAN-Enabled Charger
- ClearSky Smart Fleet™ Hardware (CS550)
- Diamond Tread Steel Deck
- Dynamic Braking
- Electric Drive
- Foot-Actuated Deck Extension
- Fork Lift Pockets
- Greaseless Kingpin Joints
- Horn
- Hourmeter
- Lanyard Attach Points
- LED Motion/Amber Beacon (CS550)
- Lifting and Tie Down Points
- Load Sensing System
- Lubrication Free Scissor Arm Bushings
- Manual Descent Cable
- Movable, Removable Platform Control
- Nickel Plated Pins
- Proportional Controls
- QuikFold Rails
- Removable Ladder
- Scissor Maintenance Prop
- Self-Closing Gate
- Steel Swing-Out Doors
- Tilt Alarm and Light
- USB Charger & Phone Holder
- Variable Tilt Visual Zone Indicator

ACCESSORIES & OPTIONS

- 4 x 6V AGM Batteries, 220 ah
- 900W Inverter
- Anti-Vandalism Package
- CleanGuard® Leak Containment System
- Coiled Platform Control Box Cable
- Drive Motor Covers
- Dual Flashing Amber Beacons - LED
- Lithium Battery (1)
- Lithium+ Batteries (2)
- MDI (Ground)
- Panel Carrier
- Pipe Racks
- SkySense® Enhanced Detection System
- White Noise Alarm

ES2646

ELECTRIC SCISSOR LIFT

SCISSOR LIFT



DIMENSIONS

All dimensions are approximate

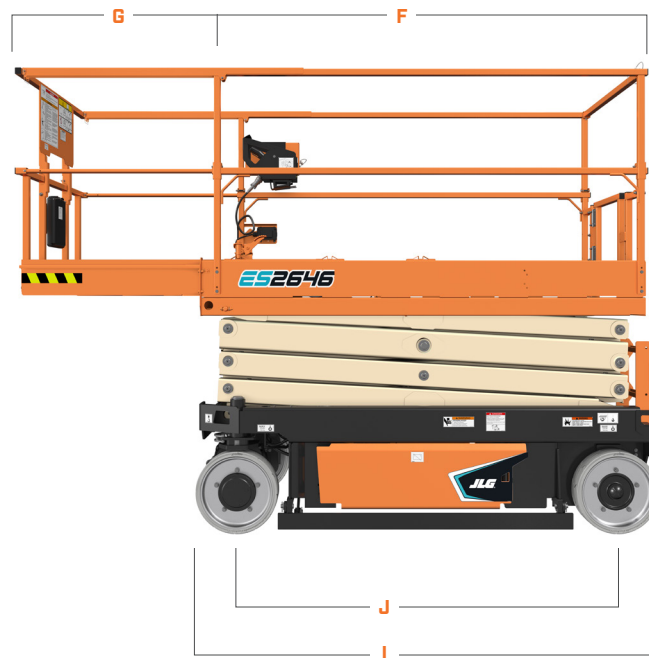
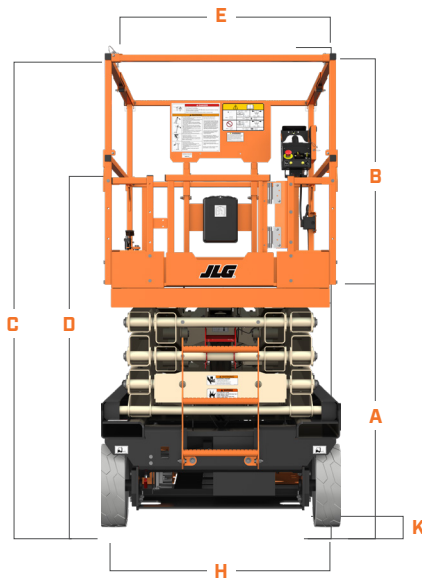

A. Platform Height (Lowered)	45-in / 1.14-m	H. Machine Width	46-in / 117-cm
B. Platform Railing Height	44.6-in / 1.13-m	I. Machine Length	94.3-in / 2.4-m
C. Machine Height (Rails Raised)	89.6-in / 2.28-m	J. Wheelbase	74-in / 1.9-m
D. Machine Height (Rails Lowered)	71.7-in / 1.82-m	K. Ground Clearance	3.9-in / 9.8-cm
E. Platform Width	41.6-in / 1.1-m		
F. Platform Length	84-in / 2.1-m		
G. Platform Extension	36-in / 91-cm		



We provide coverage for one (1) full year, and cover all specified major structural components for five (5) years. Due to continuous product improvements, we reserve the right to make specification and/or equipment changes without prior notification. This machine meets or exceeds applicable ANSI and CSA requirements based on machine configuration as originally manufactured for intended applications. Please reference the serial number plate on the machine for additional information.



JLG INDUSTRIES, INC.
Toll-free US 877-JLG-LIFT
JLG.com

An Oshkosh Corporation Company