

WSTX30/35

Counterbalance Walkie Truck



Max Load Capacity
3,000 lbs / 3,500 lbs
(1,360 / 1,587 kg)

CLARK

WSTX 30/35 Walkie Pallet Stacker

■ ADVANCED ELECTRICAL COMPONENTRY

Minimize downtime and maintenance requirements with the regenerative braking and brushless AC motor on the WSTX30/35. The infinitely variable travel controller and AC drive motor ensure high torque through the driving range, ensuring optimal performance. Travel speed remains constant relative to the throttle position, regardless of the truck load, providing superior operator ergonomics and ease-of-operation. The EPD (emergency power disconnect) shuts off all power to the system when activated, and can be reset with a simple twist.

■ BRAKES

The electromagnetic brakes on the WSTX30/35 reduce the total cost of ownership, by eliminating the need for costly brake jobs. The brakes are mounted to the motor armature shaft, multiplying the braking power through the transmission. The brakes are automatically applied when the control arm is in the fully lowered or raised position. Additionally, travel speed is reduced when the truck is in operation and the forks are raised. When the WSTX30/35 comes to rest on an incline, the position hold feature on the electromagnetic brakes prevent rollback.

■ CONTROLS

The ergonomic control handle includes travel, lift, and lower functions, designed for operation with either hand. The lift and lower controls are fully proportional, allowing operators to maneuver with ease. Standard equipment includes a wrap around handguard, reverse switch, dual butterfly thumb controls, and a horn.

■ SERVICEABILITY

The WSTX30/35 is easy to maintain and even easier to service, with a removable power head cover that exposes the major hydraulic and electrical components. Reduce overall operating costs and maintenance time with the WSTX30/35.

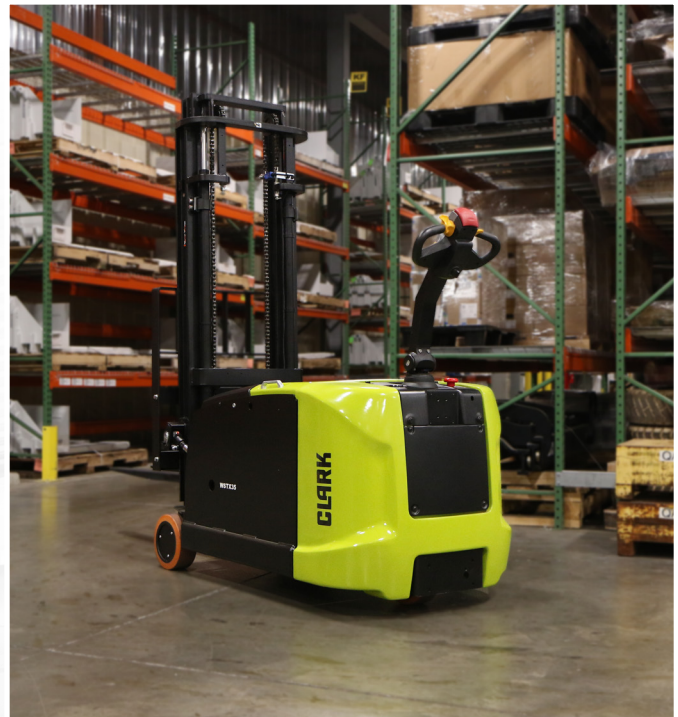

■ HYDRAULICS

The self-contained hydraulic power unit is sealed against dust and dirt, extending the life of your truck for years to come. The pressure-compensated valve regulates the lowering speeds, promoting operator safety and smooth descent of the forks.

■ FRAME AND MAST

The WSTX30/35 is Built to Last[®], with a heavy-duty frame that is compact but durable. The I-beam mast adds stability and strength to the WSTX30/35, with dual lifting chains and integrated lift cylinders in line with the outer I-beam.

■ TRANSMISSION

Reduce noise and maintenance cost while improving efficiency and performance with the state-of-the-art optimized gear technology within the transmission of the WSTX30/35. The vertically mounted drive motor is directly mounted to the gear housing, boosting efficiency.

WSTX 30/35 Specifications

Model	Upright	Lift Height (A)	O AHL (C)	Free Lift (D)	Ext. Height w/LBR (E)	Gradability		Weight*
						Loaded	Unloaded	
3,000 lbs. Capacity @ 24" Load Center, ITA Class II Fork Carriage								
WSTX30	Two Stage	104"	72.4"	5.9"	140"	5%	8%	4532 lbs.
WSTX30	Two Stage	126"	83.4"	5.9"	162"	5%	8%	4598 lbs.
WSTX30	Triple Stage**	157"	71.75"	35.6"	193.5"	5%	8%	4895 lbs.
3,500 lbs. Capacity @ 24" Load Center, ITA Class II Fork Carriage								
WSTX35	Two Stage	104"	72.4"	5.9"	140"	5%	8%	4620 lbs.
WSTX35	Two Stage	126"	83.4"	5.9"	162"	5%	8%	4686 lbs.
WSTX35	Triple Stage**	157"	71.75"	35.6"	193.5"	5%	8%	4983 lbs.

* Estimated Shipping Weight without battery

**Derate 200 lbs. above 126", additional derate with sideshift option.

Aisle Guide

WSTX30/35 Right Angle Stacking:

Load Width	Load Length		
	36"	40"	48"
36"	106"	109"	117"
40"	107"	110"	118"
48"	109"	112"	119"

For ease of use add 6" to 12" to Right Angle Stack listed.

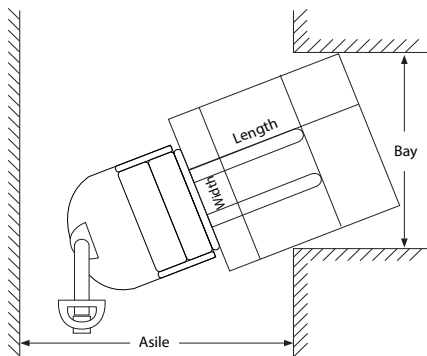

Aisle dimension listed above assume 4" between loads. Use the larger dimension; load width or load length. For ease of use and add 6" to 12" for operator clearance to the appropriate specifications listed above. Truck performance may vary due to application requirements and changes in model design.

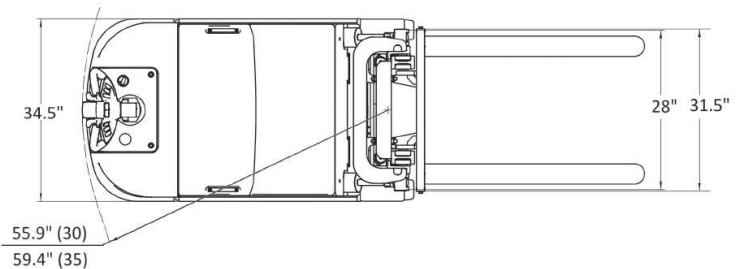
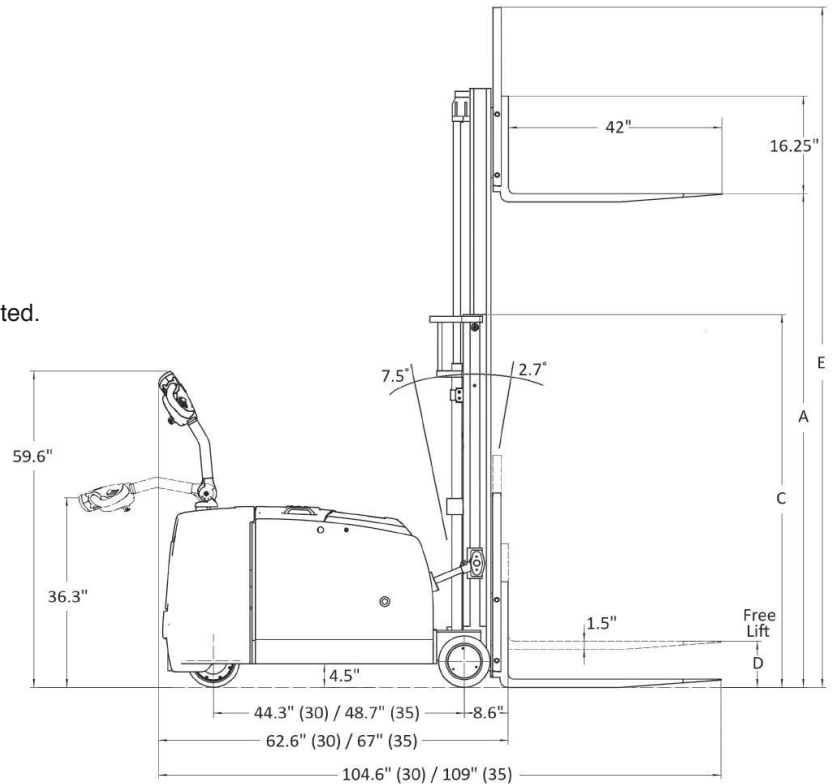



CLARK: The Innovative and Durable Solution

The design, development, and manufacturing capabilities of CLARK, in combination with an unparalleled focus on customer support, a drive to understand fully each customer’s needs in order to then supply the right solution, reflect the key essence of what is CLARK.

With over one million CLARK lift trucks sold around the world, each is a testament to the CLARK time-tested process of designing durable trucks with precise features that meet, if not exceed, the material handling needs of our customers. Our full range of dependable products – from pallet jacks to electric narrow aisle order selectors and up to our big 18,000lb capacity lift trucks – assures end-users CLARK has the solutions for their day-to-day needs.



These solutions built from industry innovations, from the nested I-Beam to a self-activating parking brake to new on-board diagnostics, began the same way: with the needs of our customers foremost in mind. By focusing on how we can improve our customers’ material handling processes, we can assure our customers a lift truck designed to be the right solution for their needs.

When you bring it all together – an extensive research and development process, state-of-the-art manufacturing capabilities, and a superior dealership network – you have a company dedicated to delivering leading edge products for both today and far into the future. More reasons why CLARK is Built to Last®.

“CLARK, and “Built to Last” are registered in the U.S Patent and Trademark office. The “Hot Yellow Green” also known as “CLARK Green” is a trademark registered in the U.S Patent and Trademark office.”



59-894-0968

CLARK MATERIAL HANDLING COMPANY
North American Headquarters
700 Enterprise Drive • Lexington, KY 40510
866-252-5275 • www.clarkmhc.com

WSXT30/35
59-894-0968 Printed in USA OTP0824150/10VR
© 2024 CLARK Material Handling Company